

EEC CONFORMITY

A - Our valves comply with European regulations (EEC) within the limits of use described in paragraph B.

The CE mark on the valve indicates conformity to the following regulations :

CE - 89/336 "Electromagnetic compatibility"
- 97/23 "Pressurized equipment"
- 73/23 "Low pressure"

B - Use limits :

Usage pressure must be lower than 10 bar for all products.

In case of dangerous gas⁽¹⁾ valve diameter (line) must be below 100 mm.

For use outside these limits, please contact our technical service.

⁽¹⁾dangerous gas : group 1 gas, identified by a letter on the label and on the security card of the product :

E (for detonating gas), O (for fuel), F+, F and R10 (inflammable), T+ and T (toxic).

For additional information, please see regulation 67/548/EC "Labeling of dangerous products".

SPARE PARTS AND ACCESSORIES

On the half-body, mark the identification number of the valve, then please see the general documentation or contact us.

Our technical services recommend the use of food grade silicone grease to reassemble the seals.

Please consult us in the event of a malfunction.



INSTALLATION GUIDE

**DPX - DPAX
BUTTERFLY VALVE**

www.definox.com

DEFINOX SAS
3 Rue de la Pépinière - Z.I. Nord
44190 GETIGNE - France
☎ : +33 (0)2 28 03 98 50
📠 : +33 (0)2 28 03 88 00

E-mail : info@definox.com

DEFINOX BUTTERFLY VALVES

MANUAL BUTTERFLY VALVE

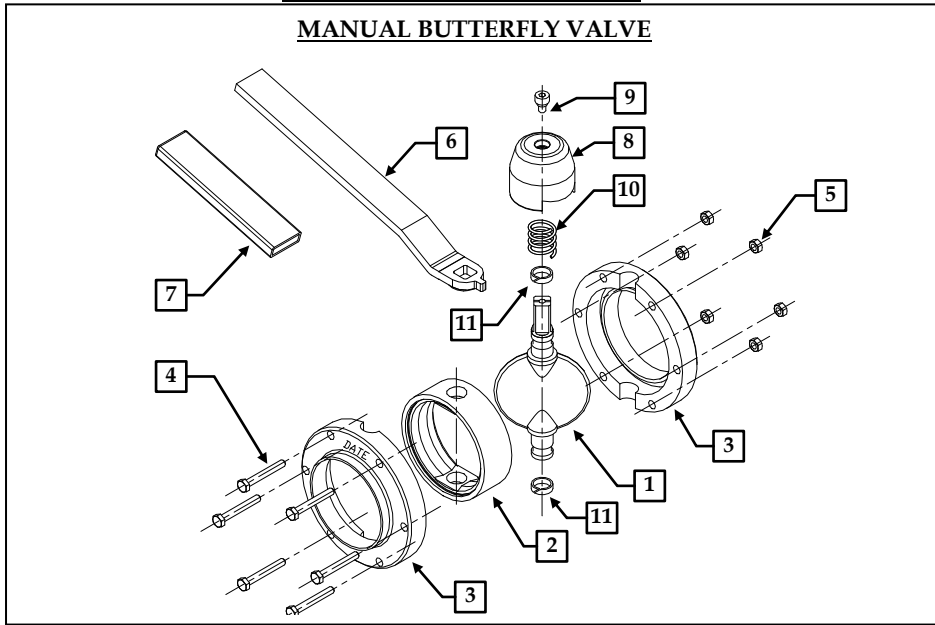

AUTOMATIC BUTTERFLY VALVE

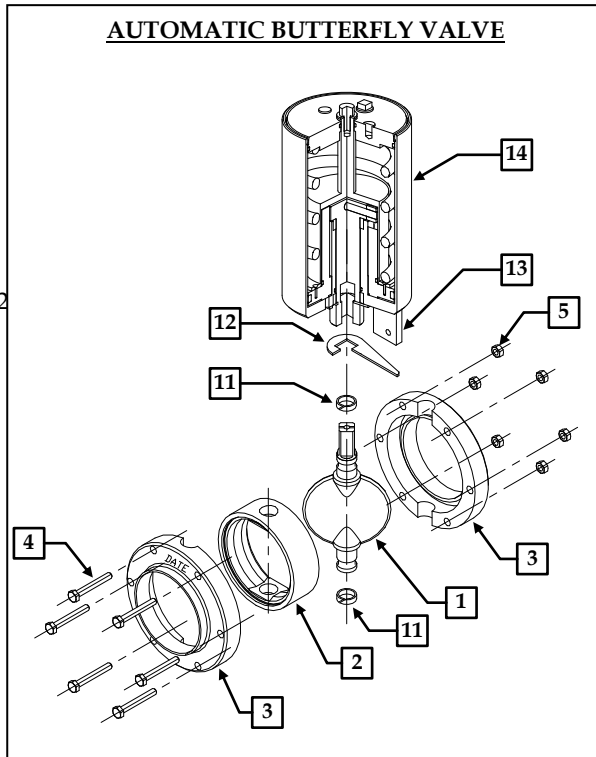

- 1 : Butterfly Disc
- 2 : Seal
- 3 : Half-body (Qty 2)
- 4 : Screw head H EF DIN 933 A2
- 5 : Nuts Hu DIN 934 Stainless Steel A2
- 6 : Handle
- 7 : Handle sleeve
- 8 : Hub
- 9 : Hub / handle screw
- 10 : Spring
- 11 : Split rings (Qty 2)
- 12 : Pointer
- 13 : Tapped feet
- 14 : Operator (Actuator)

Follow the fitting and operating instructions carefully. Take account of the actual working conditions and comply with the valve specifications indicated in the DEFINOX catalogue.

VALVE IDENTIFICATION

DEFINOX butterfly valves have an identification number on the valve half bodies **3**. You will need this number to identify any spare parts you may request.

USUABLE SEALS

The following seal types can be mounted on your valve:

NEOPRENE, EPDM, SILICONE, FOOD GRADE VITON, ACID-RESISTANT VITON

The technical department is at your disposal to help you choose the seal types best suited to your process. Ensure that the grease used is compatible with elastomere seals, particularly EPDM.

VALVE INSTALLATION

Your equipment should be stored in its original packaging with the disc **1** in the open position to prevent damage to the valve and to avoid marking the seal. Disassemble the actuator assembly disc seal **1 2 4 5 14** or the handle disc seal **1 2 4 5 6 7 8 9 10 11** before welding the half bodies **3** on the process line. Pay attention to the linear centering and rotation of the half bodies **3** (risk of jamming and excessive operating torque). The half-bodies must be aligned precisely and held in position during welding operations (possible use of a centering rod to replace the flap axes **1**). Never use the half bodies **3** to secure poorly aligned pipes. Provide disassembly fittings or the option to separate the pipes for later disassembly of the valve during maintenance operations (replacing the seal).

ASSEMBLING MANUAL BUTTERFLY VALVES

Make sure the flap **1** is positioned correctly on its seal **2** before positioning the disc between the two half-bodies **3**. The gradual tightening of the lock **4 5** is performed with the disc **1** in the closed position. Using a reference movement, make sure that the disc **1** turns normally and that complete closure does not cause an abnormal torque. To prevent an unintentional release, fit the screws with **4 5** to the threadlocker. The square male end of the disc rod **1** receives the square female end of the handle **6**. Pay attention to the respective position of the parts during assembly (a groove on the top of the disc rod **1** indicates the direction of the disc inside the valve). To correctly position the handle **6** on the half-body **3**, it is necessary to press in the bush **8** using a hammer, otherwise the disc **1** will be pulled by the screw **9** and will center poorly on the seal, with a subsequent risk of a leak occurring.

ASSEMBLING AUTOMATIC BUTTERFLY VALVES

Assemble the disc **1**, the seal **2** and the half-bodies **3** as per assembly for the manual valve, however, do not fit the two tops screws. For assembly in normally closed position, make sure the disc **1** is in the closed position (a groove on the top of the disc rod **1** marks the direction of the disc inside the valve), position the pointer **12** on the disc **1** as shown in the drawing. Assemble the operator **14** so that the holes on the half-bodies **3** face the feet tappings **13**. Supply the actuator with air to ensure that the tap functions correctly. The actuator is supplied with dry, filtered air at a minimum pressure de 4.5 bars. The air couplings fitted to the operator are suitable for the connection of flexible tubing with a diameter of 4/6.

.../...